



# Aluminum Landscape Edging Specifications & Technical Data

## I. General

### 1.01 Description

Landscape edging as a border between planting beds, pathways, drives, mulch & rock division, or anywhere separation and definition is required.

### 1.02 Submittals

Manufacturer's literature along with a sample 3" section of specified size and finish if requested.

### 1.03 Delivery

Can be coordinated directly with manufacturer or authorized distributor of Sure-loc Edging. Call 1-800-787-3562 for quotations and material coordination. Material should be ordered and accepted in original shipping cartons of standard size. Please note quantities per box on inside of brochure. Material should be stored in a flat area with boxes protected from rain.

## II. Product

### 2.01 Product

As manufactured by Sure-loc Corporation of Holland, MI. Edging to be in 16' or 8' sections.

### 2.02 Material

Edging to be manufactured from 6063 extruded aluminum alloy of T-6 hardness with interlocking system and 5 stake punch-outs fabricated in each 16' strip or 3 stake punch-outs for each 8' strip.

### 2.03 Locking System

Sections to lock together without offset or double thickness at the joints and secured with two 12" stakes at every joint.

### 2.04 Thickness (Size)

Aluminum edging available in 1/8" thickness for residential or light commercial applications where flowing curves are desired. Applications include, but are not limited to, bed division, walkways, and light brick paver work.

3/16" thickness is available for commercial, industrial, and institutional applications where strength and durability are a concern. Applications include, but are not limited to, walkways, asphalt borders, running tracks, and maintenance strips.

### 2.05 Depth

Aluminum edging of either thickness available in 4" or 5.5" depths.

### 2.06 Finish

Mill finish constitutes a natural aluminum finish as found on extruded parts.

Black anodized is available in all sizes. Finish is not a paint but rather a die that is electrically absorbed into the outer layers of the metal.

Painted finish available in Black, Brown, or Green Paint. Available in 1/8" x 4" size only (both 8 ft & 16 ft sections).

### 2.07 Stakes

Stakes to be a minimum of 12" long, secured 1/2" below top of edging, and locked into place. Stakes to be placed on inside of bed areas.

## III. Execution

### 3.01 Site Inspection

Check to ensure that all underground lines, irrigation hoses, and other cables are installed below the maximum depth of edging to be used.

### 3.02 Trench

Edge all landscape beds, maintenance strips, and/or where noted on design plan. Define the area to be edged using string, garden hose, or paint. Using a spade or mechanical trencher, cut a trench along area to be defined to depth so top of edging will not exceed 1/2" above finished grade.

### 3.03 Installation

Install edging with radius edge and ridges pointing up. Stake pockets should be on inside of bed.

### 3.04 Staking/Connecting

5 stakes per 16' section and 3 stakes per 8' section are included with material. Stakes are to lock 1/2" below top of edging and to be placed in every available pocket.

### 3.05 End Stake Adapters

Use supplied end stake Adapters at all start/stop points as well as to splice pieces of cut edging together.

### 3.06 Back Filling

Back fill on both sides of edging during installation, leaving no more than two sections unsupported at one time. Compact back fill along edging ensuring that top edge is no more than 1/2" above finish grade.

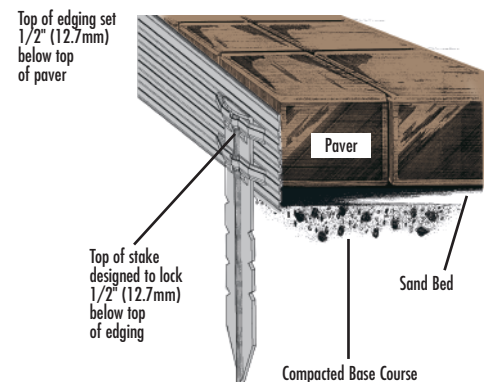
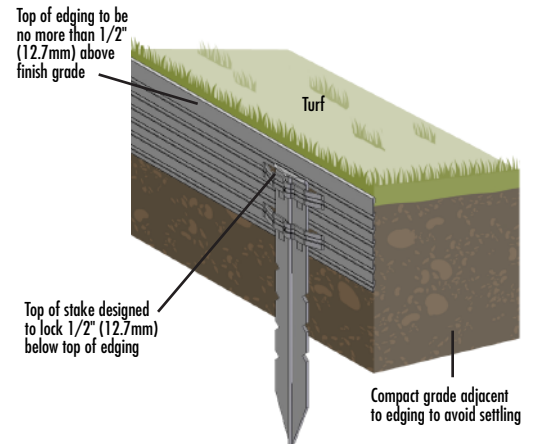

### Architect Specifications:

All Aluminum landscape edging shall be \_\_\_\_\_ thick X \_\_\_\_\_ deep X \_\_\_\_\_ long with \_\_\_\_\_ stakes per section, having a \_\_\_\_\_ Finish as painted or anodized at the factory, as manufactured by Sure-loc Aluminum Edging Corporation and under its trade name Sure-loc.

Sure-loc Edging Corporation  
494 E. 64th Street  
Holland, MI 49423  
Phone (800) 787-3562  
Fax (616) 392-5134  
Website: [www.surelocedging.com](http://www.surelocedging.com)